

LEFT OR RIGHT SIDE SNAP OUT SECTION TO ALLOW SERVICES ROUTING

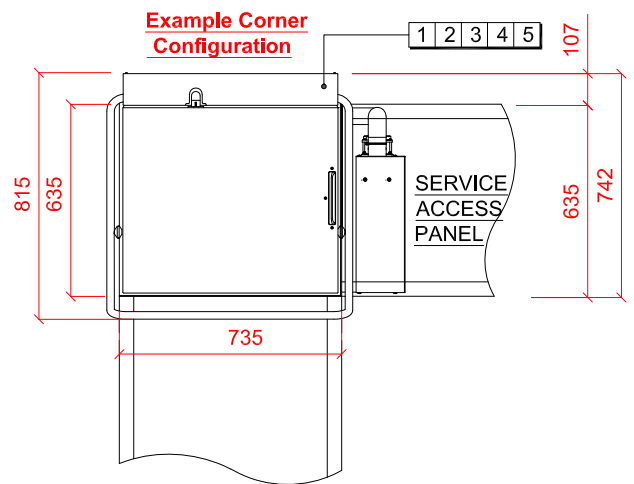
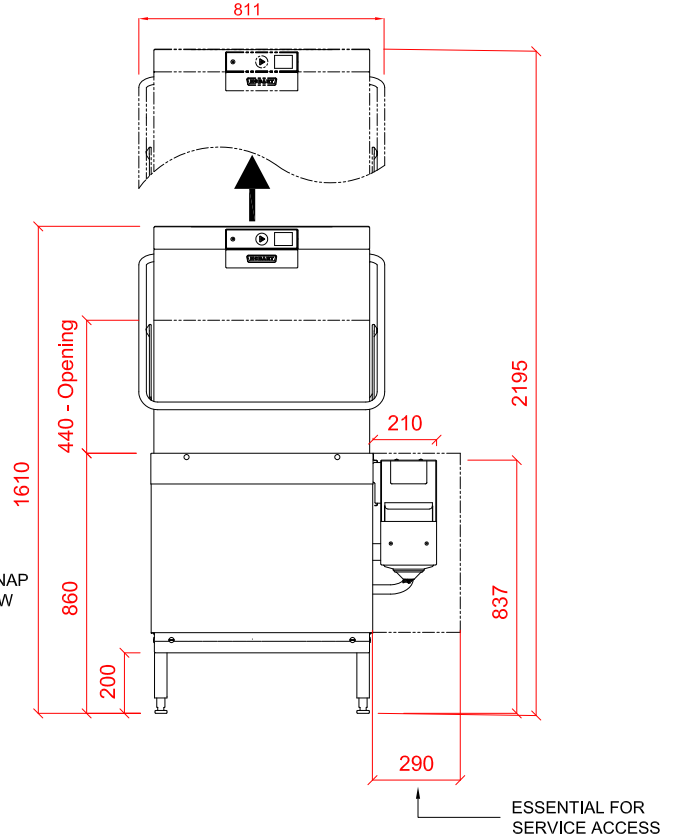

1 Water

22mm CONNECTION VIA 2 METRE FLEXIBLE HOSE, FEMALE TERMINATION.
COLD WATER SUPPLY 10°C @ 0.8 TO 10 BAR MAX.
OR
HOT WATER SUPPLY 60°C @ 0.8 TO 10 BAR MAX.
INITIAL TANK FILL 40 LITRES.
RINSE WATER USAGE (ECO) 1.4 LITRES PER CYCLE.
RINSE WATER USAGE 2.0 LITRES PER CYCLE. MAX USAGE 140 LITRES PER HOUR.
OUR MACHINES ARE SUPPLIED WITH CLASS 'AB' AIR GAP AS STANDARD.

2 Drain

DRAIN - 2 METRE FLEXIBLE HOSE TO A 40 mm TRAPPED STANDPIPE 500mm MAX A.F.F.L.

FLOW RATE 30 LITRES PER MINUTE.
DRAIN RATE TYPICALLY 3 MINUTES.

3 Electric

17.5kW 400/50/3 + N + E
FUSED AT 35amps / PHASE.
CONFIGURABLE TO:
11.3kW 400/50/3 + N + E
FUSED AT 25amps/ PHASE.
SUPPLIED WITH 2.5 METRES OF CABLE.

4 Other Services

RINSE AGENT HOSE - 2.5 METRE FLEXIBLE.
DETERGENT HOSE - 2.5 METRE FLEXIBLE.

Notes

Approx Weights: EMPTY: 130kg WITH WATER: 150kg
Min distance to Wall to Inside of tabling boxed edge 154.5mm.
HEIGHTS MARKED * REPRESENT ±20mm.
AUTOMATIC SOIL REMOVAL UNIT CAN BE POSITIONED ON EITHER SIDE OF MACHINE.