

# ECOMAX PLUS SERIES

GLASSWASHERS



## Undercounter Glasswasher

ECO+G415-11D



1 2 3

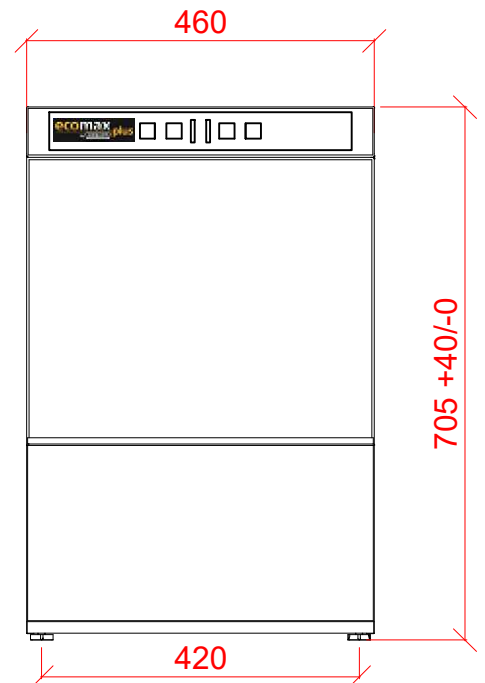
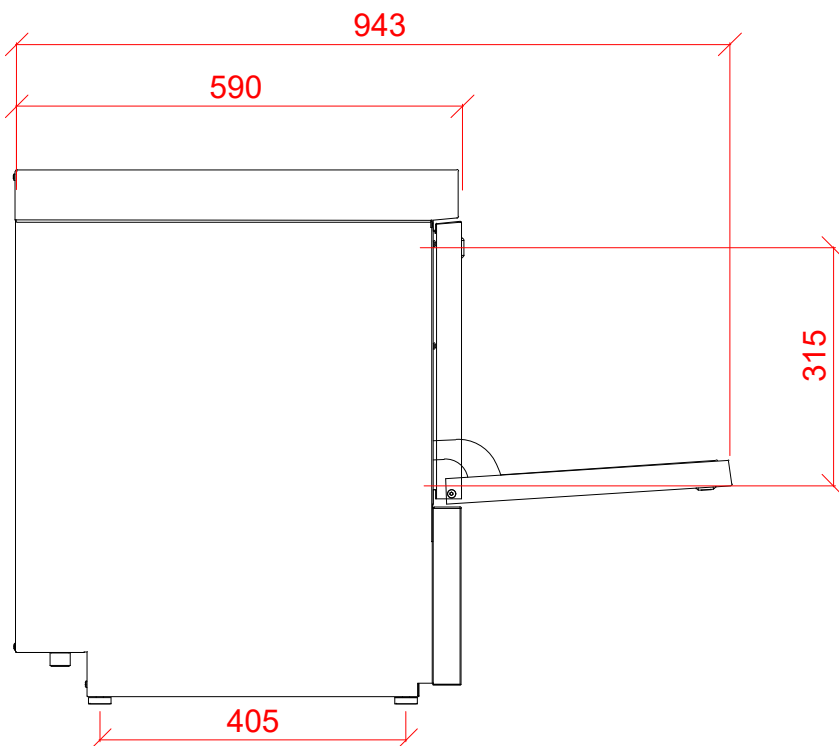
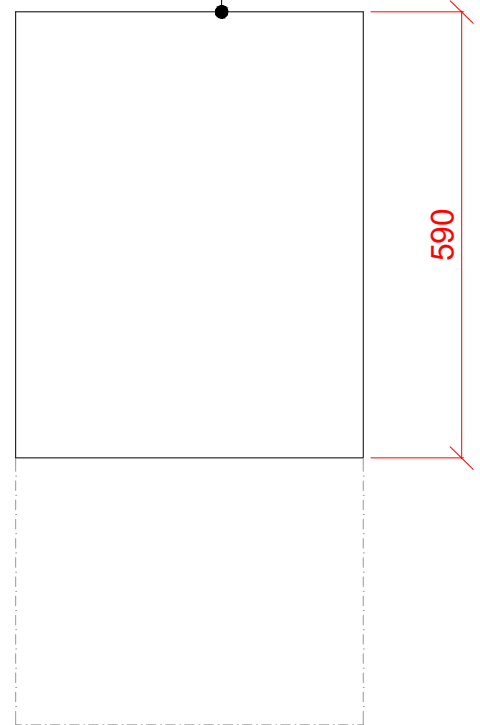

### 1 Water

22mm CONNECTION VIA 2 METRE FLEXIBLE HOSE, FEMALE TERMINATION.

WATER SUPPLY 10°C TO 60°C (2° TO 8° CLARK MAX)@ 0.6 TO 10.0 BAR MAX. INITIAL TANK FILL 8.0 LITRES. RINSE WATER USAGE 1.8 LITRES PER CYCLE. MAX USAGE 60 CYCLES PER HOUR. OUR MACHINES ARE SUPPLIED WITH CLASS 'AB' AIR GAP AS STANDARD.

### 2 Drain

2 METRE FLEXIBLE HOSE TO A 40 mm TRAPPED STANDPIPE 600mm MAX A.F.F.L.

FLOW RATE 30 LITRES PER MINUTE.

### Other Services

RINSE AGENT HOSE - 2.5 METRE FLEXIBLE. DETERGENT HOSE - 2.5 METRE FLEXIBLE.

### 3 Electric

2.6kW 230/50/1 FUSED AT 13 amps. CONFIGURABLE TO; 4.0kW 230/50/1 FUSED AT 20 amps or 5.4kW 400/50/3 FUSED AT 16 amps

MACHINE SUPPLIED WITH 1.5 METRES OF CABLE

### Notes

APPROX WEIGHTS: EMPTY: 50kg's WITH WATER: 62.5kg's +40mm FEET HEIGHT ADJUST

PLOT SCALE: 1:10

RIGHT TO MAKE NECESSARY CHANGES IS RESERVED