

ECOMAX PLUS SERIES

UNDERCOUNTER



Undercounter Dishwasher

ECO+F515W-10C

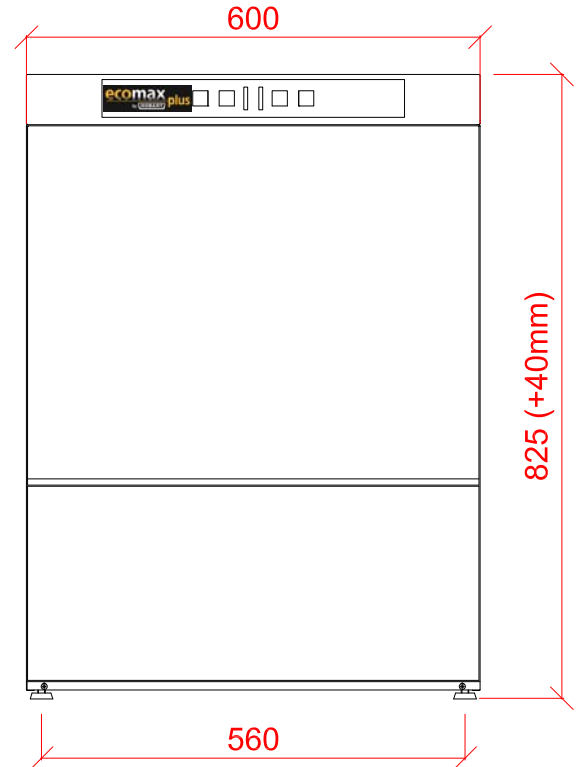
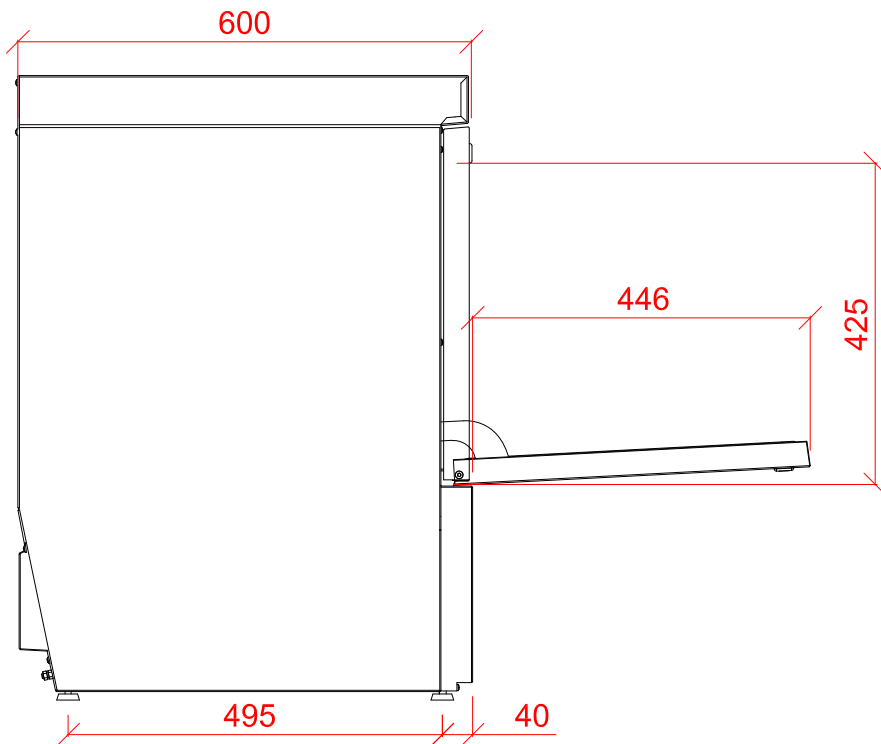
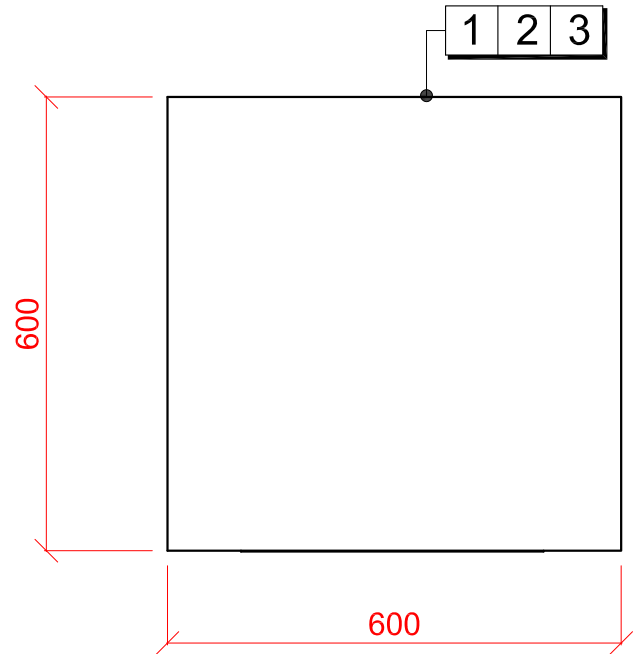

1 Water

22mm CONNECTION VIA 2 METRE FLEXIBLE HOSE, FEMALE TERMINATION. WATER SUPPLY 10°C TO 60°C @ 0.6 TO 10.0 BAR MAX. INITIAL TANK FILL 10.6 LITRES. RINSE WATER USAGE 2.3 LITRES PER CYCLE. MAX USAGE 60 CYCLES PER HOUR.

OUR MACHINES ARE SUPPLIED WITH CLASS 'AB' AIR GAP AS STANDARD.

2 Drain

DRAIN - 2 METRE FLEXIBLE HOSE TO A 40 mm TRAPPED STANDPIPE 750mm MAX A.F.F.L.

FLOW RATE 30 LITRES PER MINUTE.

Other Services

RINSE AGENT HOSE - 2.5 METRE FLEXIBLE. DETERGENT HOSE - 2.5 METRE FLEXIBLE.

3 Electric

5.5kW 230/50/1 + N + E FUSED AT 25amps

CONFIGURABLE TO:

7.5kW 400/50/3 FUSED AT 16amps/ PHASE.

MACHINE SUPPLIED WITH 2.5 METRES OF CABLE

Notes

APPROX WEIGHTS:
EMPTY: 65kg's WITH WATER: 87kg's
+40mm FEET HEIGHT ADJUST

PLOT SCALE: 1:10