

Plan View Showing Suggested Install/Service access Clearances

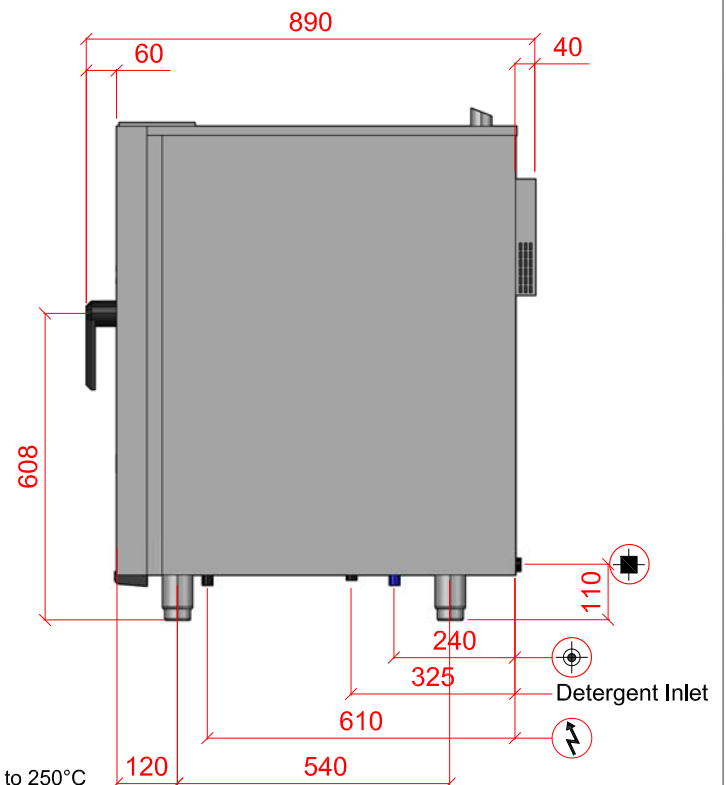
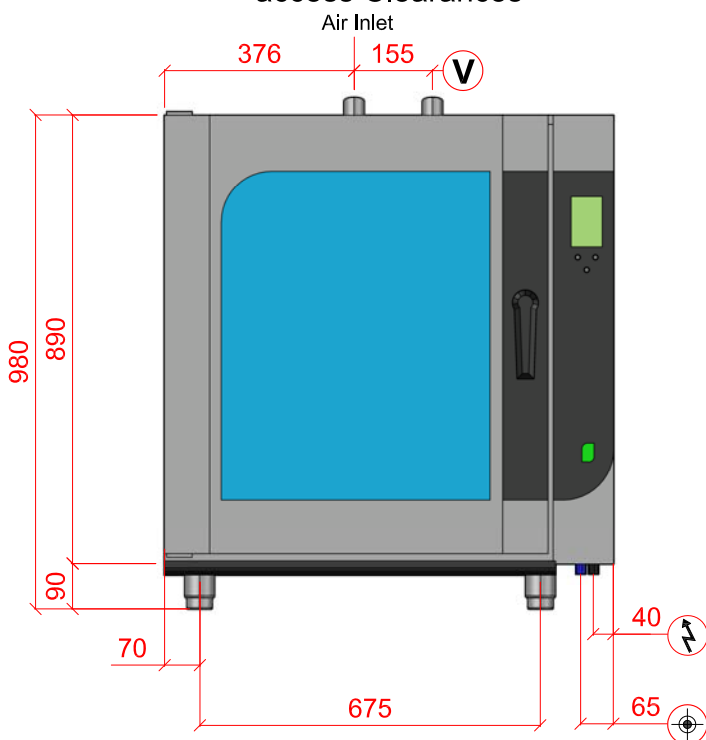

Temperature Cooking Range - 40 to 250°C

Water	Drain	Electric Loading	Vent Outlet
3/4" B.S.P. POTABLE WATER, 2.0 TO 4.0 BAR MAX PRESSURE. MAX TEMP: 30°C (2 TO 5° CLARK MAX) <b>5°e, 70ppm - MAX WATER HARDNESS PERMITTED.</b> <b>WATER QUALITY:</b> <b>MAXIMUM CONCENTRATION OF CHLORIDE Cl:100mg/l AND CHLORINE Cl<sub>2</sub>:0.2mg/l</b>	1" DRAIN CONDENSATE TEMPERATURE APPROX 98°C	18.5kW 400/50/3 + N + E FUSE AT 26.7 AMPS/PHASE	Ø40mm RECOMMENDED EXTRACTION FLOW 390m <sup>3</sup> /hour
<b>SPECIAL NOTE: DO NOT INSTALL UNIT CLOSE TO HOT APPLIANCES ON CONTROL PANEL SIDE UNIT SHOULD BE LOCATED UNDER A VENTILATION CANOPY.</b>			
<b>RECOMMENDED TO BE USED WITH A WATER TREATMENT SYSTEM.</b>			
WEIGHT 160kg net		RIGHT TO MAKE NECESSARY CHANGES IS RESERVED	

ELECTRICAL CONNECTION  
 WATER CONNECTION  
 DRAIN  
 VENT OUTLET