

View on 'A'

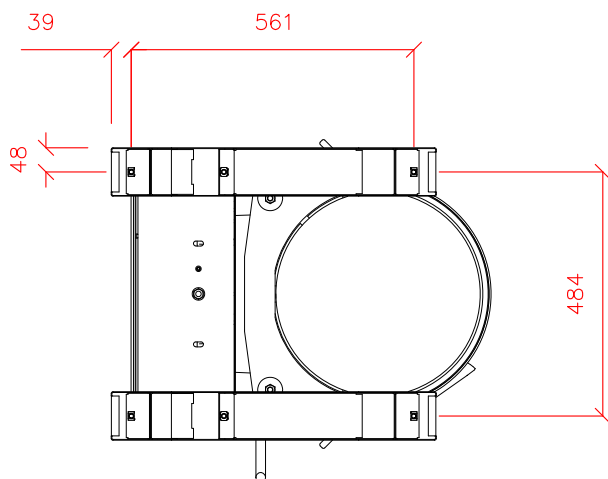

View on 'B'



**1** Electric - (3 Phase Supply)

1.1kW - 400/50/3 Recommended to be fused at 10amps

**2** Weight

Mixer weight including agitator and bowl (empty) - 205kg  
Shipping weight (on wooden pallet). - 223kg